



**CWR**

Concrete Water Recycling

**MIXER WASHING  
PLANT**





# CWR

Concrete Water Recycling

*“The three Cs for the founders and their companies’ success are: Capacity, Competence, Courtesy.”*

# COMPANY

## Company

Matec specializes in the design and development of waste water purification and filtration plants. We work for many different industries, the most important are: aggregates, gravel, sand, coal, stone, iron-ore, ceramics and glass.

Matec's mission is our customers' satisfaction. That is why we offer timely after-sale service, as well as before-sale advice to understand the real requirements of our potential customers.

Matec has installed over 250 purification plants all across the world in the last two years: this is the real guarantee of our production and service quality.

The two partners have decades-old experience in the purification industry and they are a continued presence in the company. That guarantees the best technical and commercial advice ever.

Matec new plants are based in Massa, in the very heart of a wide industrial zone, also known as Apuana. A well-equipped reality that can cope with all the needs of the worldwide purification market, thanks to a simple but effective organization.

All the machines are built in our plants. Thus we can offer top-quality products 'Made in Italy', which will fulfill the most demanding applications and markets.



# CWR - MIXER WASHING PLANT

Matec is a leader and the leading producer of hi-tech machinery for filtration of water derived from trucks, mixers, pumps and concrete, and generally all water derived from the process.

Waste water and sludge treatment arising from washing processes in concrete production sites.

Matec designs and manufactures complete CWR (Concrete Water Recycling) filtration plants. By using the filter press, our plants treat waste water and sludge arising from various washing processes.

Matec CWR plants are designed to maximize the returns of concrete production sites and to recover and re-use washing water, which has been clarified automatically and without using chemical additives. Thus we can guarantee cutting down disposal costs, also thanks to the production of dry cakes easy to shovel and move.

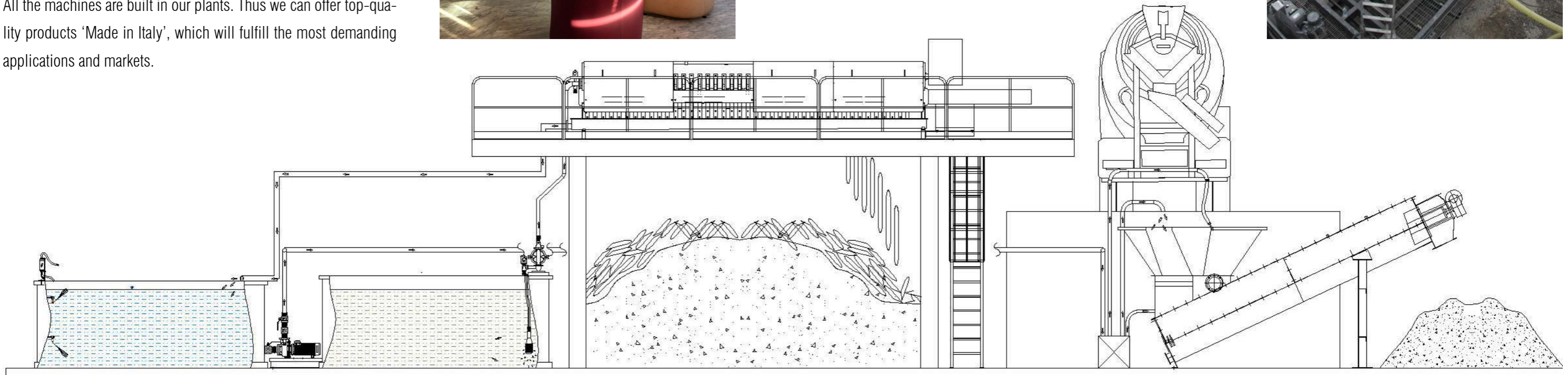
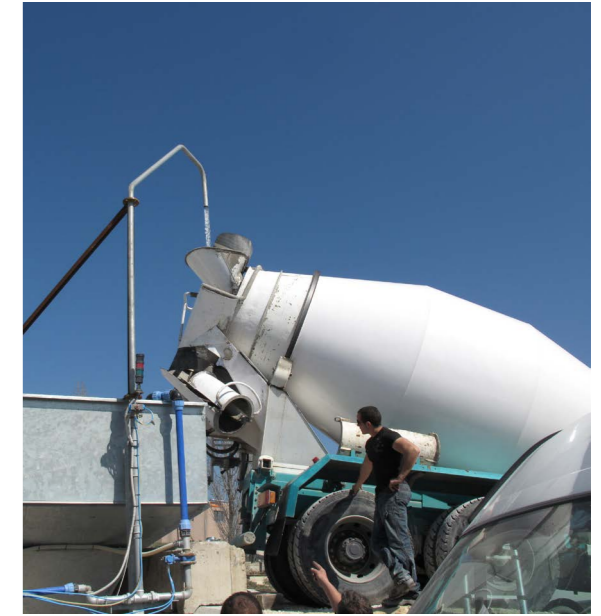

# Acquæ 400x400 CWR

Perfect for filtration plants of washing water in the cement sector.

Acquæ 400. It is named after the Latin word for Water, because it was created as a project designed for the recovery of water even in case of minimum flow rates. Because water is life!

The Acquæ is our small-medium range. It includes the technical specifications of the bigger machines simplified for uses in fields such as:

- Cement sector, CWR for the recycling of concrete recovered from cement mixers;
- Ceramic sector, factories with flow rates of waste water up to 90m<sup>3</sup>/h;
- High Technology and refinement mining sector.

## Benefits

- 100% Made in ITALY. 100% Made in Tuscany
- HPT (High Pressure Technology) to work at more than 20 BAR
- Gasser Shakers for discharging the cakes perfectly
- Real automatic washing for a complete washing
- Filter cloths attached with strips and rubber connection for an easy replacement
- Open filtrate design allows a simple and rapid identification of bad filter cloths
- Allen Bradley PLC with remote monitoring and assistance
- Number of installed plates can be up to 50 in all presses
- More than 10 models for the best economical/technical solutions

- All made of single-block steel from thick slabs*
- Plasma, laser or water-jet manufacturing process*
- The purified water is drained through 4 external manifolds (to avoid external contacts or leaks)*
- First choice components by major manufacturers*
- Stainless steel accessories*
- High speed and high pressure hydraulic system*
- Gasser Shaker automatic system for discharging the cakes*
- Cloth and plate automatic washing*
- PLC switchboard to control the whole system electronically.*

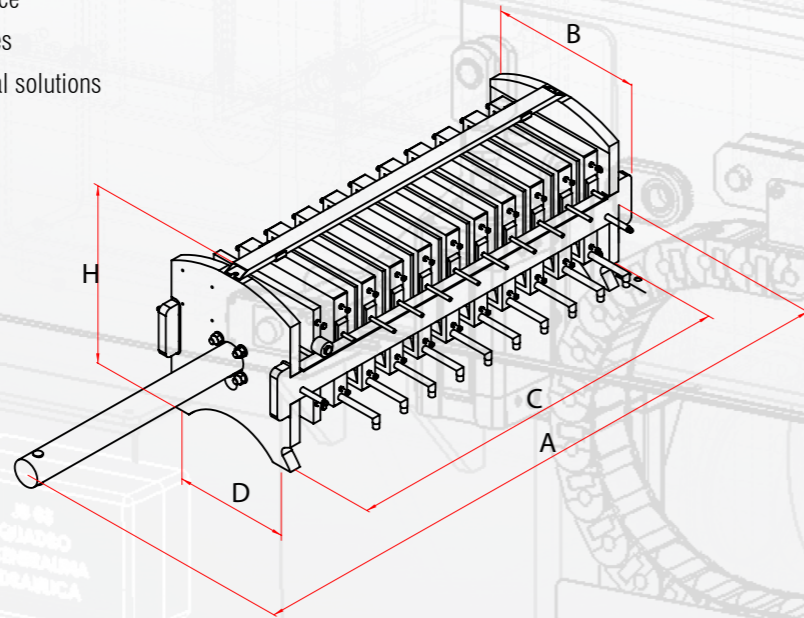

## Specifications

Acquæ model 400x400	A Length	B Width	C Foot Footbase	D Foot Footbase	H Total Height	Dry Weight (Kg)	Chamber Volume (Liters)	Capacity per cycle (Liters)	m <sup>3</sup> /h (2 cycles)	Ton/h	m <sup>3</sup> /h (3 cycles)
400/3	2485	770	750	430	800	350	4,9	9,80	0,02	0,04	0,03
400/5	2485	770	750	430	800	350	4,9	24,50	0,05	0,09	0,07
400/10	2485	770	1340	430	800	450	4,9	49,00	0,10	0,18	0,15
400/15	3235	770	1932	430	800	500	4,9	73,50	0,15	0,27	0,22
400/20	3235	770	1932	430	800	600	4,9	98,00	0,20	0,36	0,29
400/25	6149	770	3712	430	800	1200	4,9	122,50	0,25	0,45	0,37
400/30	6149	770	3712	430	800	1300	4,9	147,00	0,29	0,54	0,44

# Acquæ 500x500 CWR

Perfect for filtration plants of washing water in the cement sector.

Acquæ 500. It is named after the Latin word for Water, because it was created as a project designed for the recovery of water even in case of minimum flow rates. Because water is life!

The Acquæ is our small-medium range. It includes the technical specifications of the bigger machines simplified for uses in fields such as:

- Cement sector, CWR for the recycling of concrete recovered from cement mixers;
- Ceramic sector, factories with flow rates of waste water up to 200m<sup>3</sup>/h;
- High Technology and refinement mining sector.

## Benefits

- 100% Made in ITALY. 100% Made in Tuscany
- HPT (High Pressure Technology) to work at more than 20 BAR
- Gasser Shakers for discharging the cakes perfectly
- Real automatic washing for a complete washing
- Filter cloths attached with strips and rubber connection for an easy replacement
- Open filtrate design allows a simple and rapid identification of bad filter cloths
- Allen Bradley PLC with remote monitoring and assistance
- Number of installed plates can be up to 50 in all presses
- More than 5 models for the best economical/technical solutions

- All made of single-block steel from thick slabs*
- Plasma, laser or water-jet manufacturing process*
- The purified water is drained through 4 external manifolds (to avoid external contacts or leaks)*
- First choice components by major manufacturers*
- Stainless steel accessories*
- High speed and high pressure hydraulic system*
- Gasser Shaker automatic system for discharging the cakes*
- Cloth and plate automatic washing*
- PLC switchboard to control the whole system electronically.*

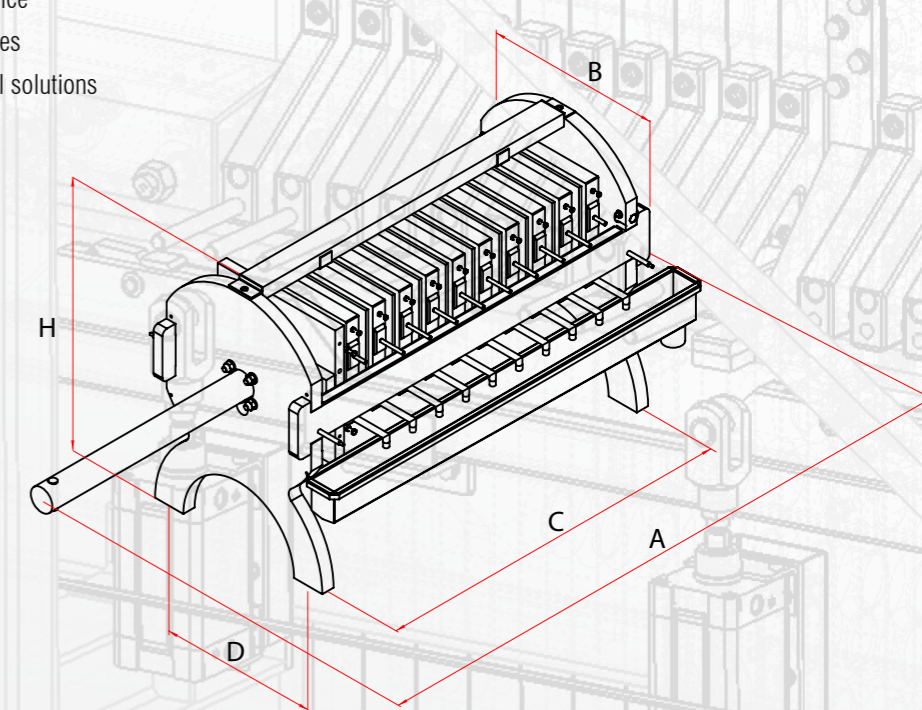

## Specifications

Acquæ model 500x500	A Length	B Width	C Foot Footbase	D Foot Footbase	H Total Height	Dry Weight (Kg)	Chamber Volume (Liters)	Capacity per cycle (Liters)	m <sup>3</sup> /h (2 cycles)	Ton/h	m <sup>3</sup> /h (3 cycles)
500/10	2.300	770	1.330	430	800	800	5,9	59,00	0,12	0,22	0,18
500/15	3.380	770	2.000	430	800	1.000	5,9	88,50	0,18	0,33	0,27
500/20	4.040	770	2.430	430	800	1.200	5,9	118,00	0,24	0,44	0,35
500/25	4.660	770	2.850	430	800	1.300	5,9	147,50	0,30	0,55	0,44
500/30	5.260	770	3.270	430	800	1.500	5,9	177,00	0,35	0,65	0,53

*matec*<sup>®</sup>  
machinery technology

PROJECT  
Laguna - Mose

*“Matec filter presses can handle all capacities and projects from 2 to 200 trucks.”*

# Acquæ 630x630 CWR

Perfect for filtration plants of washing water in the cement sector.

Acquæ 630. It is named after the Latin word for Water, because it was created as a project designed for the recovery of water even in case of minimum flow rates. Because water is life!

The Acquæ is our small-medium range. It includes the technical specifications of the bigger machines simplified for uses in fields such as:

- Cement sector, CWR for the recycling of concrete recovered from cement mixers;
- Ceramic sector, factories with flow rates of waste water up to 500m<sup>3</sup>/h;
- High Technology and refinement mining sector;
- Recycling sector, flow rates up to 60 m<sup>3</sup>/h.

## Benefits

- 100% Made in ITALY. 100% Made in Tuscany
- HPT (High Pressure Technology) to work at more than 20 BAR
- Gasser Shakers for discharging the cakes perfectly
- Real automatic washing for a complete washing
- Filter cloths attached with strips and rubber connection for an easy replacement
- Open filtrate design allows a simple and rapid identification of bad filter cloths
- Allen Bradley PLC with remote monitoring and assistance
- Number of installed plates can be up to 50 in all presses
- More than 7 models for the best economical/technical solutions

- All made of single-block steel from thick slabs*
- Plasma, laser or water-jet manufacturing process*
- The purified water is drained through 4 external manifolds (to avoid external contacts or leaks)*
- First choice components by major manufacturers*
- Stainless steel accessories*
- High speed and high pressure hydraulic system*
- Gasser Shaker automatic system for discharging the cakes*
- Cloth and plate automatic washing*
- PLC switchboard to control the whole system electronically.*

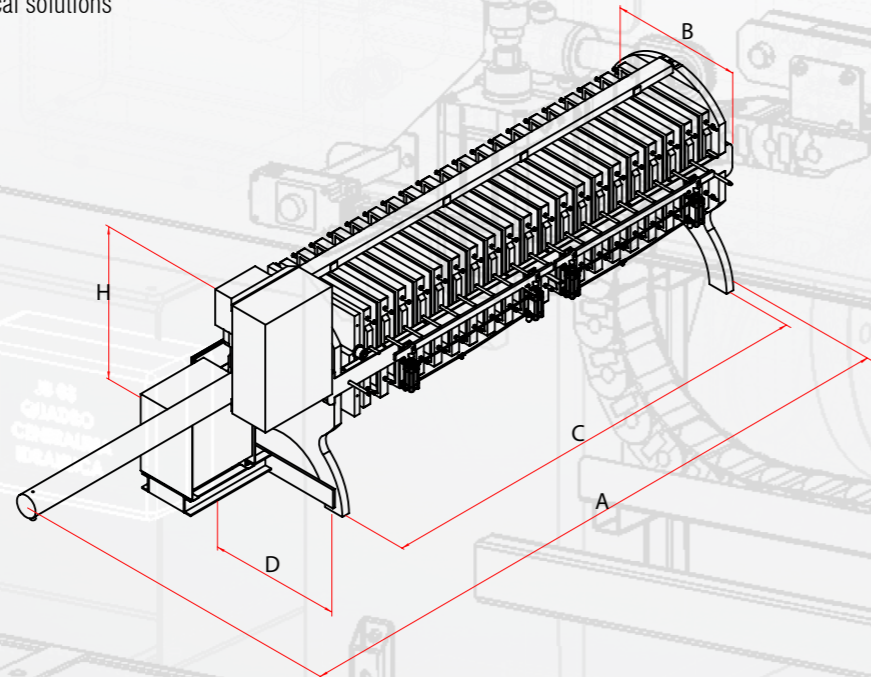

## Specifications

Acquæ model 630x630	A Length	B Width	C Foot Footbase	D Foot Footbase	H Total Height	Dry Weight (Kg)	Chamber Volume (Liters)	Capacity per cycle (Liters)	m <sup>3</sup> /h (2 cycles)	Ton/h	m <sup>3</sup> /h (3 cycles)
630/10	2.880	1.200	1.545	770	1.565	2.600	12,5	125,00	0,25	0,46	0,38
630/15	5.290	1.200	2.885	770	1.565	3.500	12,5	187,50	0,38	0,69	0,56
630/20	5.290	1.200	2.885	770	1.565	3.500	12,5	250,00	0,50	0,93	0,75
630/25	6.175	1.200	3.555	770	1.565	3.800	12,5	312,50	0,63	1,16	0,94
630/30	7.300	1.200	4.255	770	1.565	4.000	12,5	375,00	0,75	1,39	1,13
630/40	9.610	1.200	5.685	770	1.565	4.300	12,5	500,00	1,00	1,85	1,50
630/50	11.825	1.200	7.070	770	1.565	4.600	12,5	625,00	1,25	2,31	1,88

# Ignis 800x800 CWR

Perfect for filtration plants of washing water in the cement sector.

Ignis 800. It is named after the Latin word for Fire, because it is created from materials welded with fire.

The Ignis is our medium range. It includes the technical specifications of the bigger machines simplified for uses in fields such as:

- Cement sector, CWR for the recycling of concrete recovered from cement mixers;
- Ceramic sector, factories with flow rates of waste water up to 900m<sup>3</sup>/h;
- High Technology and refinement mining sector;
- Recycling sector, flow rates up to 120 m<sup>3</sup>/h.

## Benefits

- 100% Made in ITALY. 100% Made in Tuscany
- HPT (High Pressure Technology) to work at more than 20 BAR
- Gasser Shakers for discharging the cakes perfectly
- Real automatic washing for a complete washing
- Filter cloths attached with strips and rubber connection for an easy replacement
- Open filtrate design allows a simple and rapid identification of bad filter cloths
- Allen Bradley PLC with remote monitoring and assistance
- Number of installed plates can be up to 70 in all presses
- More than 10 models for the best economical/technical solutions

- All made of single-block steel from thick slabs*
- Plasma, laser or water-jet manufacturing process*
- The purified water is drained through 4 external manifolds (to avoid external contacts or leaks)*
- First choice components by major manufacturers*
- Stainless steel accessories*
- High speed and high pressure hydraulic system*
- Gasser Shaker automatic system for discharging the cakes*
- Cloth and plate automatic washing*
- PLC switchboard to control the whole system electronically.*

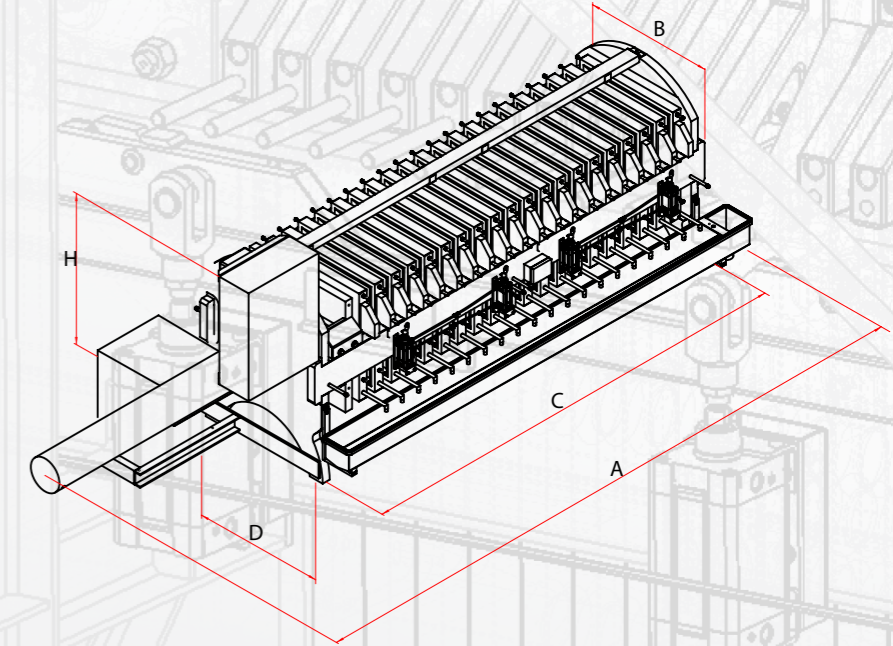

## Specifications

Ignis model 800x800	A Length	B Width	C Foot Footbase	D Foot Footbase	H Total Height	Dry Weight (Kg)	Chamber Volume (Liters)	Capacity per cycle (Liters)	m <sup>3</sup> /h (2 cycles)	Ton/h	m <sup>3</sup> /h (3 cycles)
800/10	4.585	1.530	2.455	890	1.760	2.600	18,2	182,00	0,36	0,67	0,55
800/15	4.235	1.530	2.455	890	1.760	3.000	18,2	273,00	0,55	1,01	0,82
800/20	5.300	1.530	3.160	890	1.760	3.600	18,2	364,00	0,73	1,35	1,09
800/25	7.900	1.530	4.575	890	1.760	4.500	18,2	455,00	0,91	1,68	1,37
800/30	7.900	1.530	4.575	890	1.760	4.500	18,2	546,00	1,09	2,02	1,64
800/40	8.120	1.530	5.980	890	1.760	5.500	18,2	728,00	1,46	2,69	2,18
800/50 New TT	5.776	1.530	4.518	890	1.760	6.000	18,2	910,00	1,82	3,37	2,73
800/60 New TT	6.398	1.530	5.140	890	1.760	6.600	18,2	1.092,00	2,18	4,04	3,28
800/70 New TT	7.206	1.530	5.948	890	1.760	7.200	18,2	1.274,00	2,55	4,71	3,82

- A - Screw conveyor**
- B - Waste water tank**
- C - Pump**
- D - Filterpress**
- E - Clean water tank**

**A**

**B**

**C**

**D**

**E**

**matec**<sup>®</sup>  
*machinery technology*

**BORN TO BE PERFECT**  
**TURNKEY WATER TREATMENT**  
**AND FILTERPRESS**

**NO PERSON, NO POLYMER, NO PROBLEMS!**

Turn Hard-To-Handle Sludge Into Easy-To-Handle Dry Cakes  
With The Matec Plate & Frame Press



1

“ The mixers/trucks are washed and the residue is discharged into the screw separator or the dewatering screen. ”

“ The dirty water is agitated in the tank (B). ”

5



2

“ The screw separator (A), or the dewatering screen, recovers washed material. ”

“ The dirty water is pumped directly into the filter press (D) by an HPT pump (C), without adding flocculant and without being clarified. ”

6



3

“ The recovered material is ready to be reused. ”

“ The filter press (D) filters the water by retaining all solids, returning completely clean water ready to be reused in the production cycle (E). ”

7



4

“ The dirty water is stored in an external tank (B) ready to be filtered. ”

“ The filter press produces dry mud cakes (max 20% of residual moisture) completing more than 5 cycles per hour and reducing sludge volume by 80%. ”

8





# Concrete recovery unit

MATEC, through its CWR plants, can recover concrete at the end of its working cycle.

MATEC offers two options for the water treatment before that the filtration and purification process is carried out by the filter press:

## SCREW SEPARATOR

The screw separator is used to separate aggregates, which will be washed during this process, from water, which still contains the finer particles and is ready to be purified by the filter press. Recovered aggregates are piled up at one end of the screw separator, ready to be reused in the concrete production cycle.

## Technical Data

Max. Production	m <sup>3</sup> /h	30 - 50
External Diameter	mm	700
Length	mm	6024
Power	Kw	7,5
Hopper Tilt Angle		24°

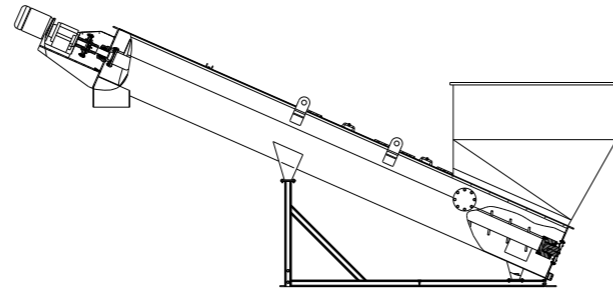

## DEWATERING SCREEN

As well as separating water from washed aggregates, the dewatering screen selects the washed materials, depending on the installed number of meshes and its holes' size and allowing concrete producers to use precise mixtures. The dewatering screen is placed over a tank, where the water falls, ready to be treated by the filter press.

## Technical Data

Decks	n°	1
Deck dimensions	mm	1210x2700
Capacity	t/h	70
Power	Kw	2,2 + 2,2
Weight	Kg	1600
Overall dimensions	mm	3158x1705x1567

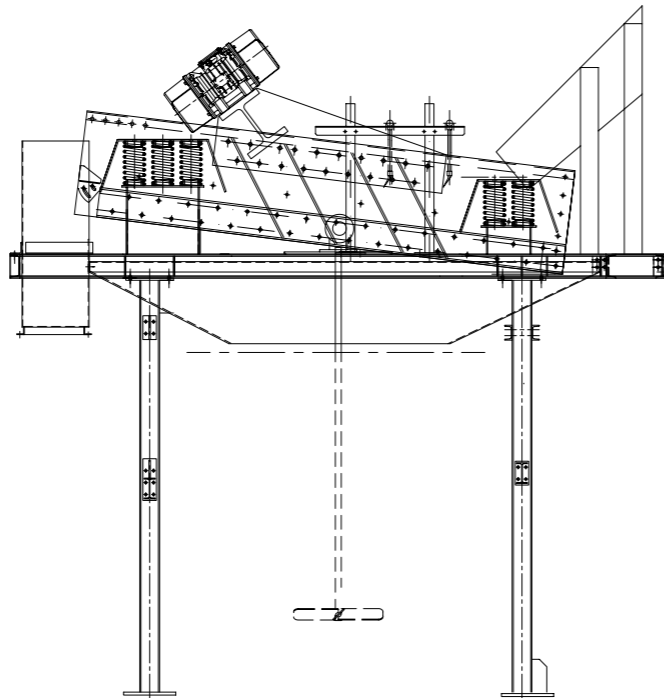

## OPTIONAL ACCESSORIES

- Submersible pump for washing water feeding;
- Submersible pump for hopper feeding;
- Electroagitators;
- Dosing system;
- Conveyor belt.

# Accessories

## CLOTH AND PLATE WASHING

Cloth and plate high pressure washing system. The washing sequence is the same as the filtering one with clean water replacing mud. The result is cleaned cloths, plates, plate conduit, piping, mud pump. Besides, the system washes 10 plates at a time to guarantee a high quality result in a very short time.

## CORE BLOW

Plate conduit and pipe cleaning system through a compressed air flow. A valve system excludes the mud pump during the air blowing sequence, avoiding damage to the pump itself.

## DRIP TRAY

Water drip collecting system. During the filtration process, a small quantity of water might drip off the plates on mud cakes. To avoid that a tray system covers the discharge hole below the filter press during the process, it will reopen in the cake discharge phase. The system can be pneumatic or mechanic.

## MEMBRANE PLATES

An additional squeezing system to further lower the residual humidity in the cakes. The membrane plates can reduce the chamber volume by pumping water in their special dead-air-space. This variation, together with the HPT MATEC High Pressure Pump, grants a lower residual humidity than standard plates.

## MUD CAKE WASHING

Close circuit system for special mud with chemicals. It usually works together with the membrane plate system, allowing a clean water flow inside the plate chambers before cakes are discharged. This process rinses the cakes, to lower chemicals' level under the "special mud" threshold.

All the MATEC filter presses can be set up on different types of support: steel or concrete ones, and metal reinforced masonries. They can be built together with protection structures, such as canopies or insulated boxes, and ladders or stairs.



matec®  
machinery technology

PROJECT  
Latomia

*“More than 200 installations all  
over the world in cement sector.”*



PROJECT  
Valley

*“Matec provides turnkey  
high-tech and easy-to-manage  
solutions.”*

# TECHNICAL Technical Support

Thanks to our highly skilled engineers, our global supplying/dealing network and our factory service personnel we can guarantee you an extensive range of services whenever you require them. Whatever business is yours it is important to us.

Matec provides all supplying/dealing service staff with a comprehensive training program. Our staff is equipped with the correct skills, exhaustive knowledge, methods and practices to support with pre-sales and after-sales service.

# QUALITY Quality & Warranty

Matec equipment is rigorously tested, with high quality standards set for each step of the manufacturing process from design to distribution. Thus we can guarantee high quality and reliability.

If you experience problems with our equipments, your local supplier can access the online warranty system to solve the problem as soon as possible. Your feedback will be also incorporated into our R&D program to continue the development of our products.

## 24 MONTHS Guarantee



Sistema di gestione aziendale certificato n° 16124/07/S  
Management system certificated n° 16124/07/S

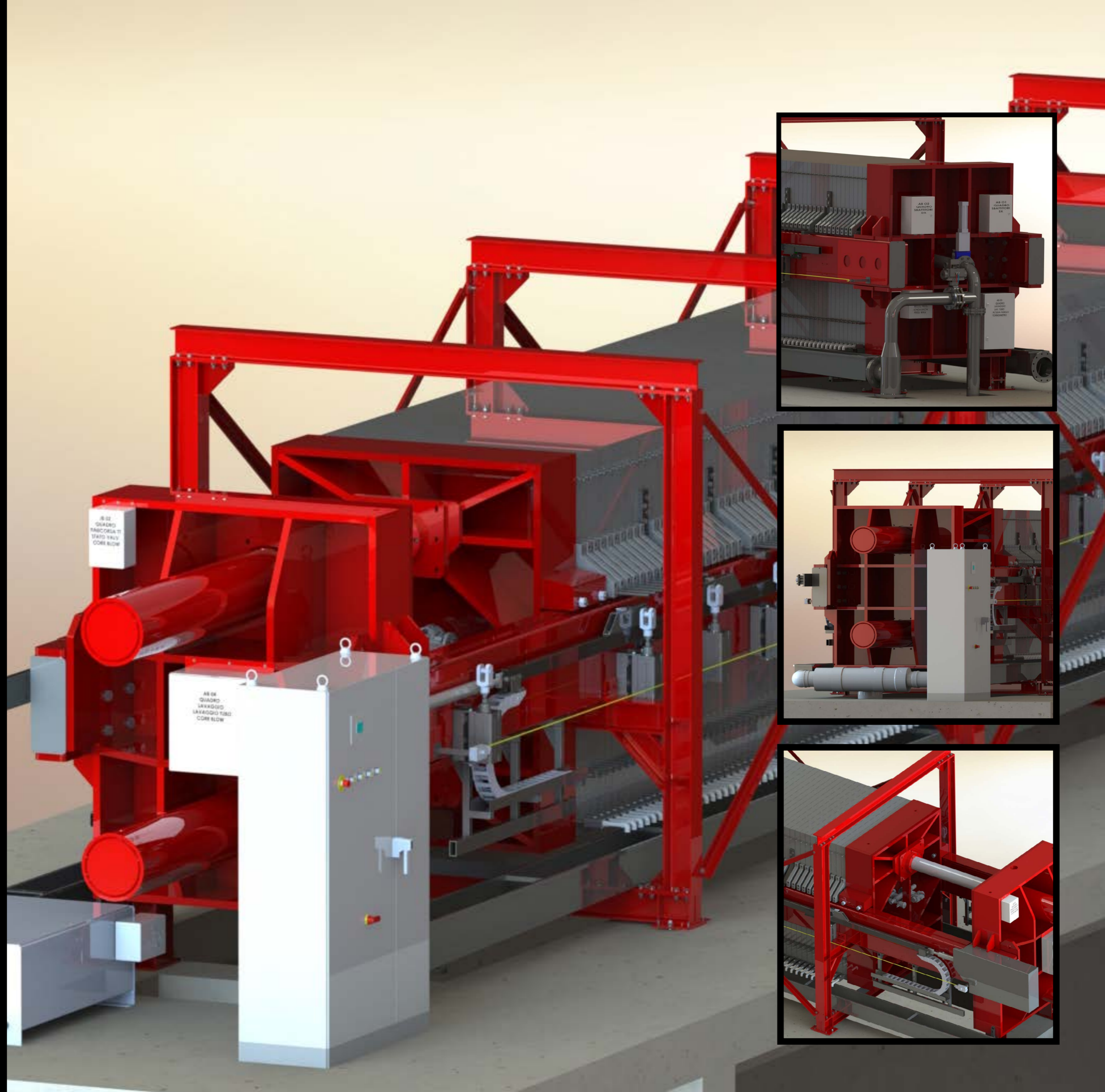



Matec Corporation S.r.l.

Via San Colombano, 13  
54100 - Massa (MS) - Italy  
Tel. +39.0585.831034  
Fax. +39.0585.835598

[www.mateccorporation.it](http://www.mateccorporation.it)



Matec America LLC

130 Plant Street  
Walnut Cove, NC 27052  
Tel. 270-841-9180  
Fax. 336-591-9254

[www.matecamerica.com](http://www.matecamerica.com)



Matec S.r.l.

Via Aurelia Ovest, 383  
54100 Massa (MS) Italy  
Tel. +39.0585.831034  
Fax. +39.0585.835598

[www.matecitalia.com](http://www.matecitalia.com)



ENGLISH